

Custom SOUNDSOAK® Acoustical Wall Systems

Installation Instructions

1.0 GENERAL

1.1 Product Description

Custom Soundsoak wall panels are available up to 4' wide and up to 10' high on 1" and 2" thick fiberglass panels. Impact-resistant panels are also available. All panels have resin-hardened edges. Panels are manufactured-to-order in square or rectangular shapes. Panel are fabric-wrapped with

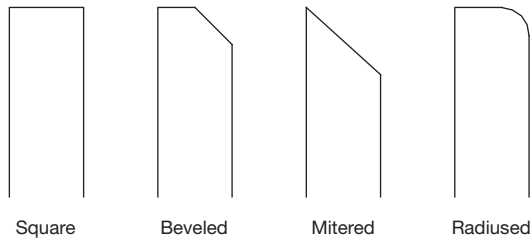

one of the following edge profile options:

1.2 Storage and Handling

Custom Soundsoak panels shall be stored in a dry interior location and shall remain in cartons prior to installation to avoid damage. The cartons shall be stored in a flat position. Proper care should be taken when handling to avoid damage or soiling.

1.3 Site Conditions

Building areas to receive wall panels shall be free of construction dust and debris. Products can be installed in conditions between 32°F (0°C) and 120°F (49°C) and in spaces before the building is enclosed, where HVAC systems are cycled or not operating. These products are not recommended for exterior applications or where standing water is present or where moisture will come in direct contact with the wall.

1.4 CAUTIONS:

1. Never cut one panel on top of another panel.
2. Any time the back of a panel is cut or scored for any reason, apply a heavy nonporous tape or foil to reseal the back of the panel to prevent air flow through the panel in these areas. This air flow can cause soiling of the fabric surface.
3. Use clean hands when handling Soundsoak panels to prevent soiling or staining of the fabric surface. Be sure the area in which Soundsoak is to be installed is clean before installing.
4. Never install Soundsoak above the ceiling line since this can create high air flow through the panel into the ceiling plenum, which can cause soiling of the fabric.

▲WARNING

Cartons of Soundsoak carry warning labels that speak to the presence of potentially hazardous glass wool or mineral wool fibers. Please read and follow all warning instructions on the carton and on the Material Safety Data Sheets.

1.5 Flexible Installation Options

Custom Soundsoak wall panels can be installed in a variety of ways.

- The typical method is with impaling clips and adhesive (clips from Armstrong, adhesive by others).
- Adhesive (by others) alone may be used.
- Z-clip installation over resin-hardened spots on the back of the panels is also an option (clips from Armstrong, screws by others).
- By special request, panels may also be manufactured with kerfed edges and installed with an internal H spline system.

The first three installation procedures will be described in the following sections.

For details on installing multiple kerfed panels with internal H splines, refer to the installation instructions for standard Soundsoak (LA-295818).

2.0 IMPALING CLIP INSTALLATION PROCEDURE

Custom Soundsoak wall panels with fabric wrapped edges can use impaling clips for installation. This type of installation requires the walls to be straight, flat, and solid.

Impaling clip installation can be used for both full panel and appliqué installations. Generally panels will not be cut except for service penetrations like receptacles and switches. Note: Impaling clip installation will keep the panel nominally 3/16" off the wall. Any field cut edges should be fabric wrapped.

If a panel must be reduced in size, an edge can be fabric wrapped by cutting only the board and not the fabric, trimming the fabric to allow a 2-1/2" flap, and wrapping the fabric over the edge and securing it to the back with adhesive or staples.

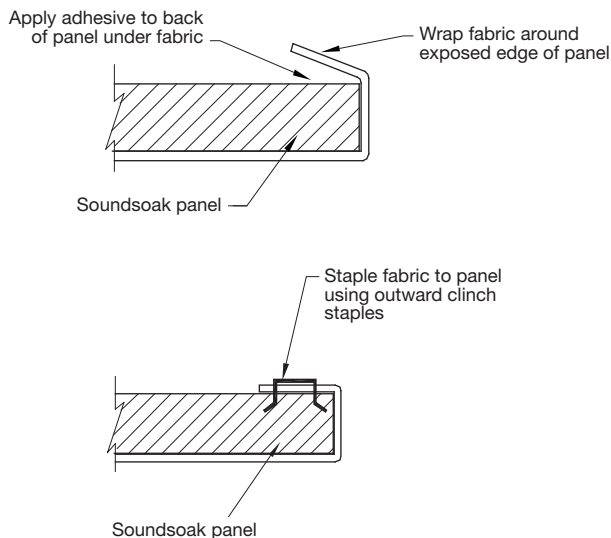
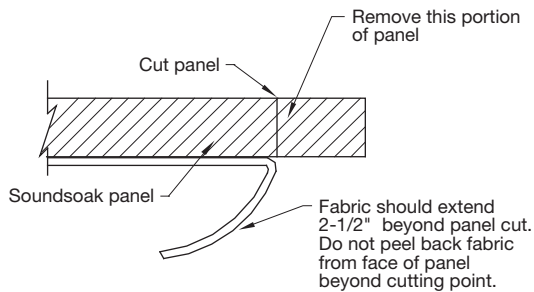

NOTE: Panels installed with impaling clips and adhesive will not be accessible or removable.

Panels must have a 1" minimum clearance between the top of the panel and the ceiling for impaling clip installations.

Tools and Additional Hardware

You'll need the following tools: plumb bob, level with straight edge or a laser, tape measure, painter's tape, screw gun, appropriate screws or fasteners to attach impaling clips to the wall, and adhesive.

2.1 Lay out the panel location on the wall. Mark the top of the final panel location on the wall using a laser or other leveling device. Make a second mark one inch higher than the first mark and also indicate the location of the sides of the panel. Use painter's tape for these marks.

2.2 Fasten the impaling clips to the wall using appropriate screws or fasteners for the wall (screws or fasteners provided by others). Refer to the chart below for the number of clips typically needed.

Panel Size (either 1" or 2" thick)	Number of Impaling Clips
Up to 4' x 4'	4
Between 4' x 4' and 4' x 8'	6
4' x 10'	8

2.3 Apply beads of construction adhesive (by others) to the face of the clips. Adhesive must be compatible for use with a fiberglass substrate and metal clips.

2.4 Tilt the top edge of the panel against the wall aligning the top of the panel with the bottom of the painter's tape and inside the side tape markings. When the panel is aligned with all of the location indicators, let the back of the panel engage the prongs on the impaling clips.

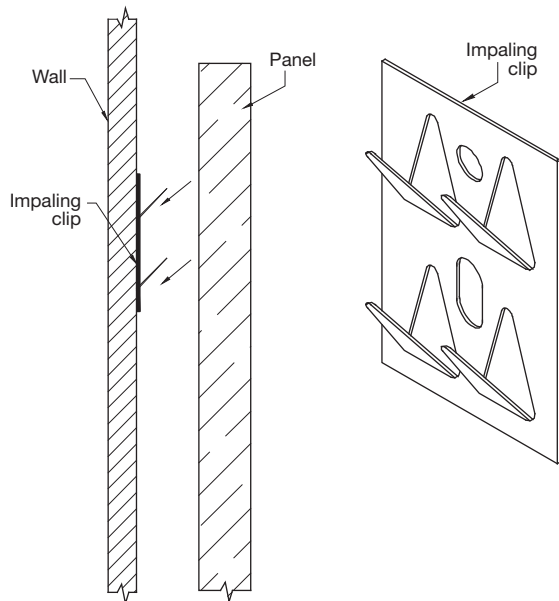

2.5 Push in and down on the panel. The panel will slide onto the prongs of the impaling clips. If the panel is not quite level, it can be adjusted slightly so that it becomes level. Prop or brace the panel level until the adhesive has set.

3.0 Z-CLIP INSTALLATION PROCEDURE

Custom Soundsoak wall panels with fabric wrapped edges and/or Custom Soundsoak panels that are designed to be removable can use Z-clips for installation. Z-clip installation requires the walls to be straight and solid.

Z-clip installation can be used for full panel and appliqué installations. Generally panels will not be cut except for service penetrations like receptacles and switches. Note: Z-clip installation will keep the panel nominally 3/16" off the wall. Any field cut edges should be fabric wrapped.

Panels installed with Z-clips are easily removed and re-installed for access behind the panel or to change patterns in multiple panel installations.

Z-clip location and spacing is critical to keep and maintain Soundsoak panel alignment.

Panel must have a 1" minimum clearance between the top of the panel and the ceiling for Z-clip installations.

If panels are ordered for Z-clip installation, the panels will be made with resin-hardened spots.

Tools and Additional Hardware

You'll need the following tools: plumb bob, level or laser, tape measure, screw gun, #10 x 5/8" truss head screws to attach Z-clip to the panel, and appropriate screws or fasteners to attach the Z-clip to the wall.

3.1 Lay out the panel location on the wall.

3.2 Install the Z-clips to the Soundsoak panel.

Attach a Z-clip with two #10 x 5/8" truss head screws (or equivalent, by others) to the appropriate resin spots on the back of the panel. Clips must be aligned straight and square.

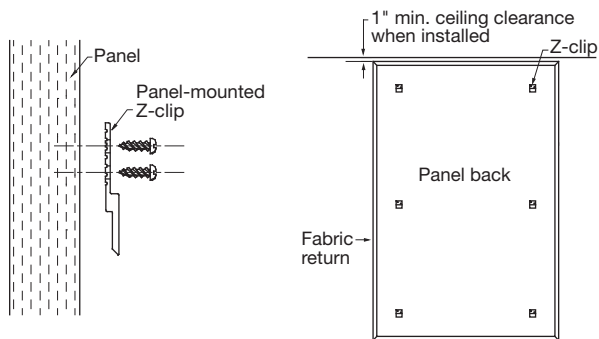

3.3 Install the Z-clips on the wall.

Determine the Z-clip location on the wall to line up with the Z-clip on the panel. Use two fasteners (appropriate for the wall substrate, provided by others) to attach the Z-clip to the wall.

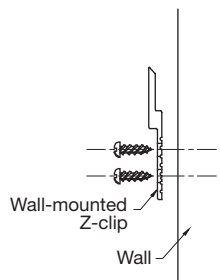

3.4 Install the panel.

Position the panel on the wall slightly above the desired height. Gently slide the panel and Z-clips down onto the Z-clips on the wall. Large panels may require two people to align and engage Z-clips.

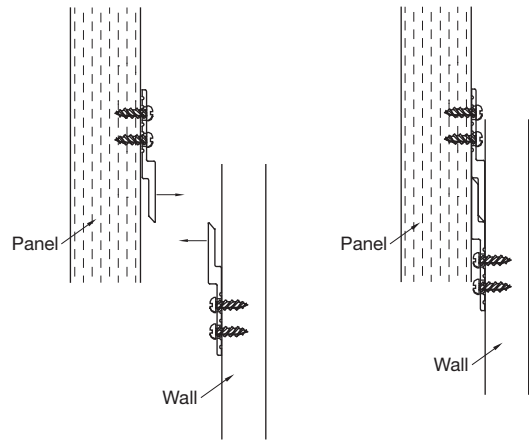

3.5 Install remaining panels. Slight panel adjustment can be made from side to side by shifting the panel. Vertical adjustment must be made by mechanically adjusting the location of the Z-clip.

4.0 ADHESIVE INSTALLATION PROCEDURE

Custom Soundsoak wall panels may also be installed using adhesive.

4.1 Apply an appropriate amount of panel adhesive (by others, follow adhesive manufacturer's directions) around the back perimeter of the panel just inside the fabric edge. Make sure the adhesive is thick enough to exceed the fabric thickness and make solid contact with the wall surface.

4.2 Position and press the panel and adhesive to the wall. Panel may need temporary support until the adhesive sets. You can use a finish nail through the panel at a slight downward angle to hold the panel in place. Set the nail head just below the fabric surface and lightly rub the fabric to hide the hole.

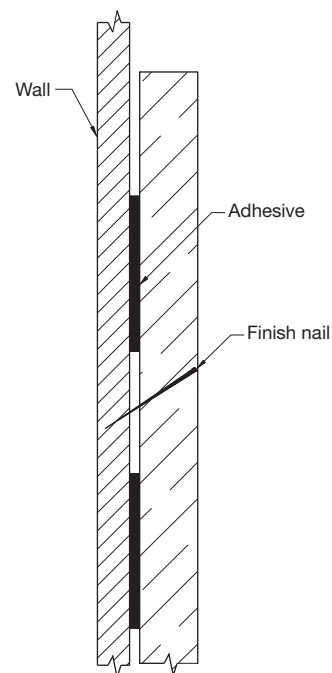

5.0 MAINTAINING CUSTOM SOUNDSOAK

- 5.1** Routine maintenance of Soundsoak wall panels should include frequent vacuuming to minimize dirt accumulation.
- 5.2** A dry or wet carpet shampoo can be used on Soundsoak fabric. A dry shampoo from a spray can is applied to the fabric as foam and worked into the fabric with a damp sponge. The residue is then vacuumed to remove the foam and dirt. A wet shampoo is a sprayed cleaning agent which foams after it is applied. Work in with a damp sponge, and vacuum to remove residue.
- 5.3** To remove stains which do not respond to removal by wet or dry shampoo (oil- or grease-type spots), use a solvent type cleaner like perchloroethylene. Be sure to have proper ventilation when using these materials. Apply the removal agent to a clean cloth or sponge, not directly to the fabric. Blot the stain, using a twisting and lifting motion toward the center of the spot. Repeat as necessary.
- 5.4** Badly soiled Soundsoak panels can be cleaned using a steam cleaning or hot water extraction process. Small residential steam cleaners can be used much in the same manner as cleaning upholstery. However, be very careful not to overwet the panel surface since this can cause fabric delamination. Commercial steam cleaners should use their upholstery tool since this applies only a fine mist and will not overwet the panel. The commercial vacuum should be reduced to about 30 psi to prevent damage to the panel.

MORE INFORMATION

For more information, or for an Armstrong representative, call 1 877 ARMSTRONG.

For complete technical information, detail drawings, CAD design assistance, installation information and other technical services, call Architectural Specialties at 1 877 ARMSTRONG and select options 1-1-4.

For the latest product selection and specification data, visit armstrong.com/soundsoak.